

Features

CPU

- ✓ High-performance 8051-compatible 8-bit CPU
 - 1 instruction = 1~3 machine cycle(s)
 - 1 machine cycle = 4 clock cycles (typical)
- ✓ CPU operating clock can be configured:
 - Internal clock: 7.5 MHz/15 MHz/30 MHz(nominal)
 - External clock: Contact smart card input CLK supply via C3 (ISO/IEC 7816)

Memories

- FLASH
 - ✓ Size: 192KB
 - ✓ Page size: 512 bytes
 - ✓ Erase and program operation: Page Erase and Byte Program
 - ✓ Typical time: erasing 4ms, programming 30µs
 - ✓ Bit logic: 1b after erasing, 0b after programming to be 0b
 - ✓ Usage: code and data
 - CODE can surmount the 64 KB limit, using CODE banking
- RAM
 - ✓ Size: 4 KB
 - 3.75 KB in XDATA
 - 256 bytes in IDATA
- OTP
 - ✓ User OTP: 224bytes
 - ✓ SN: 17 bytes

Algorithms and Peripherals

- Symmetric algorithms
 - ✓ DES/T-DES
- Peripherals
 - ✓ CRC: 16-bit CRC-CCITT
 - ✓ TRNG: True Random Number Generator, for secure transactions
 - ✓ Timer: One 16-bit timer, one ETU timer

Interfaces

- ISO/IEC 7816-3 serial interface
 - ✓ UART supporting ISO/IEC 7816-3 T=0/T=1 protocol and 11 baud rates:
F/D = 11H, 12H, 13H, 18H, 91H, 92H, 93H, 94H, 95H, 96H, 97H
 - ✓ Interface DMA supported
 - ✓ Null byte 60H sent by hardware automatically
 - ✓ Support GSM power consumption standards, including Clock Stop mode



THC20F08AD-B Contact Smart Card IC

192 KB FLASH
4 KB RAM

Beta

**Security**

- ✓ Scrambling data storage
- ✓ High/low voltage and high/low clock frequency detectors
- ✓ CLK filter (ISO/IEC 7816 external clock)
- ✓ Security Certification: EAL4+

Work parameters (Note1)

Symbol	Name	Conditions	Min	Typical	Max	Unit
TDES	Time for Executing 64-bit DES Encryption	Single DES		17		clock cycle
TPE	Time for Erasing a Page		1	4	5	ms
TBP	Time for Program a Byte		25	30	35	μs
TDR	Data Retention		10			year
NPE	Page Endurance		100000			Cycle
f _{EXT}	External Clock Freq.		1		5	MHz
f _{INT}	Internal Clock. Freq.		7.5		30	MHz
V _{CC}	Supply Voltage		1.62		5.5	V
I _{CC}	Supply Current	V _{CC} = 5.0V		5	10	mA
		V _{CC} = 3.0V		4	6	mA
		V _{CC} = 1.8V		3	4	mA
I _{SB}	Standby Current (Clock Stop)	V _{CC} = 5.0V		70	200	μA
		V _{CC} = 3.0V		60	100	μA
		V _{CC} = 1.8V		50	100	μA
T _{AMB}	Ambient Temperature		-25		85	°C
V _{ESD}	ESD Protection	HBM	4			kV

Note1: This document is a preliminary version, data and descriptions (including this table) can not be a formal evidence for performance and functions of the IC.

Descriptions

THC20F08AD-B is an 8-bit CPU contact smart card IC with a total of 192 KB FLASH and hardware DES/TRNG/CRC, suitable for general IC card applications, such as SIM card, banking card, Pay-TV card, campus card, city card, etc.

COS developers can flexibly partition the 192 KB FLASH to store code and data.

COS can access all FLASH area from CODE, because the 64 KB limit can be surmounted by CODE banking. To facilitate software development, the IC embeds hardware DES/ TRNG/ CRC. COS developers can enjoy smaller code size and less execution time.

For better security and reliability, the IC offers many hardware security features, e.g., high/low voltage and high/low frequency detection, etc.

Structure

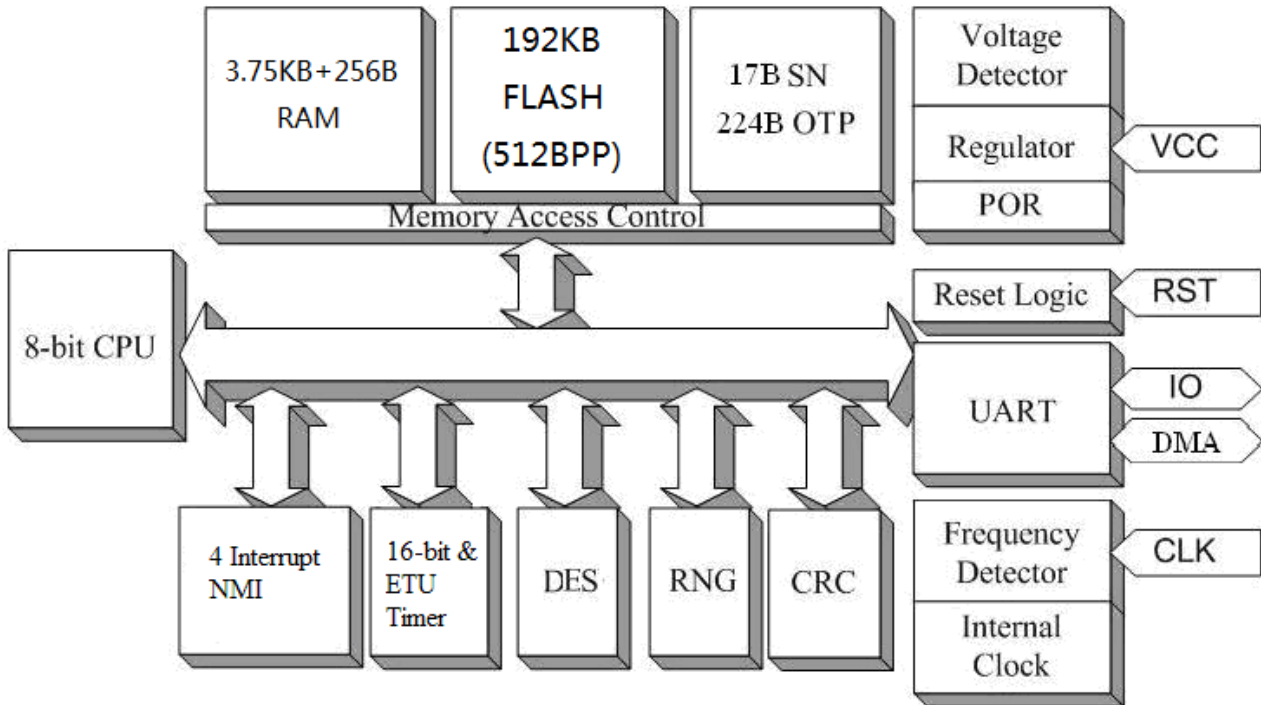

Development Toolkits

- ✓ SCDS series Hardware Emulator(Target board inside)
- ✓ IDE:Keil uVision2/3/4
- ✓ Demo project and API(Application Program Interface)codes
- ✓ User Manual and Application Notes
- ✓ The UDVG software tool to generate COS downloading script with user desired format

Package and Pin Definitions

Different packages are available, e.g., wafer / module / card, etc.

Listed are pin definitions for a card package.

Signal Name	Function Descriptions	Contact defined in ISO/IEC 7816-2
VCC	Power Supply Voltage	C1
GND	Ground	C5
CLK	Clock Input	C3
RST	Reset Signal	C2
I/O	Data Input/Output	C7
NC	Not Connected	C4, C6, C8



Important Notice

The publication must be encrypted and e-mailed to the qualified customer (person / organization) whose official e-mail address has been water-printed as signature. Other kinds of delivery are forbidden, and Beijing Tongfang Microelectronics Co. Ltd. (TMC is short for the company name hereinafter) reserves the right to pursue this matter through legal channels.

TMC reserves the right to make changes to its product specifications and this document without notice; customer could get the latest version of product specifications and this document by contacting the contact point mentioned in the end page. TMC assumes no responsibility, for any loss, harm or other consequences resulting from the use of information contained herein.

TMC recommends the product described in this document being used for the application it is designed to; detailed qualification is recommended before the judgment of suitability. TMC makes no warranty or guarantee regarding the suitability of its products for any particular purpose, includes but not limited to aircraft, space, military, medical and life-support system; and TMC assumes no responsibility for such use.

This document could not be the evidence to transfer intellectual property mentioned herein, includes but not limited to patent, trade mark or software copyright.

Contact Us

Beijing Tongfang Microelectronics Co., Ltd

Address: Floor 18th, Building D, Tsinghua Tongfang Hi-tech Plaza,
No.1 Wangzhuang Road,
Haidian District,
Beijing 100083,
P.R.China

Tel.: +86-10-82351818

Fax: +86-10-82357168

Email: support@tsinghuaic.com